



**CU PRO - User manual**

# **ELITE CU PRO**

## **User Manual**



Version September 2023



**THIS PAGE IS NOT WRITTEN INTENTIONALLY**



# 1. FIRST STEPS

Congratulations on your purchase of the ELITE model CU PRO knives grinding machine.

**Read this guide before you start.**

The ELITE CU PRO model is our most advanced manufacturing and sharpening knives machine. It features a grinding head designed to prevent corrosion better than standard painted grinding heads and equips a direct drive motor which lets you have 20% more engine power compared to other engines that incorporate belt transmission. Its design and programming make it possible to optimize grinding work in an agile and safe way.

This manual introduces you to the main functions of the grinder in order to avoid risks to your health or that may cause a breakdown or premature wear of the machine.

In case of any doubt, please contact us directly or one of our authorized distributors.

*Informative Note: The use described in the manual of this knives grinder described therein may present some variations in use as our machinery is subject to possible construction modifications, depending on the incorporation of technological advances in our sharpening equipment.*



## 2.SAFETY

### 2.1.Safety regulations

Carefully observe and apply the following safety rules, not respecting these rules may cause personal injury or damage to the machine itself.

The installation and maintenance of the machine described in this manual must be carried out only by operators who are familiar with its operation and have sufficient technical knowledge.

The ELITE model CU PRO have been designed for the sharpening and grinding of knives, excluding any other type of operation.



DANGER HIGH VOLTAGE



DANGER OF ACCIDENT



DANGER DUE TO SPARK PROJECTION



WEAR PROTECTIVE SHOES



DANGER FROM SHARP TOOLS



USE HEARING PROTECTORS

These warnings do not include all possible risks that improper use of the machine could cause. For this reason, the operator must proceed with prudence and observing the rules.



## 2.2. Use and storage of the instruction manual

This instruction manual must be read and understood by all personnel who come into contact with the machine.

This manual is for:

- Indicate the correct use of the machine according to the type of work to be carried out.
- Provide the necessary instructions for the transport, adjustment and maintenance of the machine.
- Facilitate the ordering of spare parts and information on risks.

Limits of use of the manual:

The machine is intended for professional use and therefore the experience of the operator is required and of vital importance.

Importance and conservation of the manual:

This manual must be considered part of the machine and must therefore be attached to it until the end of its use.

Additional information and clarifications:

The user, owner or maintenance person can contact the manufacturer to request any additional information on the use of the machine and possible modalities for maintenance and repair intervention.

Expiration of responsibility:

The manufacturer is considered exempt from any liability in the event of:

- Improper use of the machine
- Use of the machine by untrained persons
- Serious failures in scheduled maintenance
- Unauthorized interventions or modifications
- Use of non-original spare parts.



## 2.3. Declaration of conformity

The company hereby **Elite Sharpening Machines, SLU**  
**C/Joan Oró, 27**  
**ES-08635 Sant Esteve Sesrovires**

declares that the product indicated below, based on its conception and construction, as well as the version put on the market by our company, complies with the mandatory basic health and safety requirements of the CE directive.

This declaration loses its validity in the event of unauthorized modifications to the product.

Product name: ***ELITE CU PRO***  
Product type: ***Sharpening and grinding knife machine***  
Serial No.: \_\_\_\_\_

EC Directive Competences:

- **EC Machinery Directive (2006/42/EC)**
- **European directive on electromagnetic compatibility (2014/30/EU)**
- **The protection purposes of the CE low voltage directive (2006/95/CE) were fulfilled according to annex I, nr. 1.5.1 of the machinery directive 2006/42/EC**

The technical documentation was compiled by Legal representative of the documentation:

**Sergi Valls Gramunt**  
**Joan Oró, 27**  
**ES-08635 Sant Esteve Sesrovires**

Date / manufacturer - Signature: \_\_\_\_\_

Signatory data: Sergi Valls Gramunt, manager



**THIS PAGE IS NOT WRITTEN INTENTIONALLY**





### 3. TECHNICAL DATA

In the following information table, find the list of technical specifications of the machine described in this manual.

TECHNICAL DATA	CU PRO
Grinding wheel motor power	Direct drive 15 HP for 50Hz - 18HP for 60Hz - 1500 RPM
Grinding wheel diameter	250 mm. (Optional 300 mm.)
Carriage speed	From 1 to 30 m/min.
Max. distance between grinding wheel and chuck	180 mm.
Magnetic chuck wide	150 mm. (Optional: 200 mm. and 250 mm.)
Coolant tank	220 liters with mechanic separation
Max. connected power	16 kW

AVAILABLE VERSIONS			
Model	Magnetic chuck size	Size	Weight
1000 mm.	1000 x 180 mm.	2200 x 1200 x 1800 mm.	990 Kg.
1500 mm.	1500 x 180 mm.	2700 x 1200 x 1800 mm.	1380 Kg.
2030 mm.	2030 x 180 mm.	3200 x 1200 x 1800 mm.	1880 Kg.
3060 mm.	3060 x 180 mm.	4200 x 1200 x 1800 mm.	2480 Kg.
4090 mm.	4090 x 180 mm.	5200 x 1200 x 1800 mm.	2980 Kg.
5120 mm.	5120 x 180 mm.	6200 x 1200 x 1800 mm.	3500 Kg.
6150 mm.	6150 x 180 mm.	7200 x 1200 x 1800 mm.	4300 Kg.

#### TECHNICAL REQUIREMENTS

- Connection voltage: 400V 3Ph 50Hz - 480V 3Ph 60Hz - 220V 3Ph 60Hz
- Required connection power: 16 kW



## 4. TRANSPORT

The ELITE model CU PRO is delivered packed in wooden jail.

During all transport and transfer, the machine must be kept in its original vertical position, any variation in this position may lead to the loss of the guarantee.



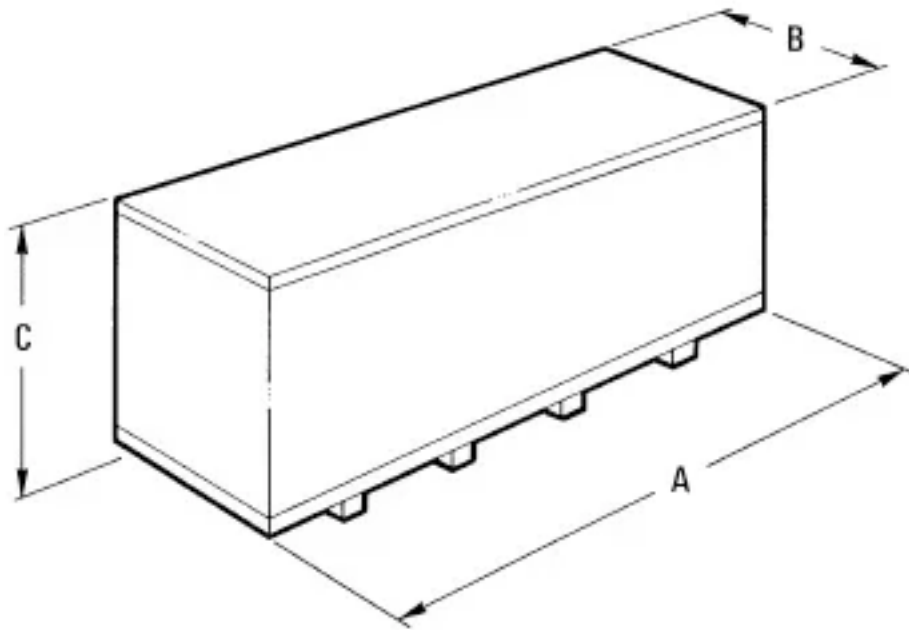

Machine model	A (mm)	B (mm)	C (mm)	Weight (kg)
CU PRO 1000	2550	1350	1950	1305 Kg.
CU PRO 1500	3150	1350	1950	1730 Kg.
CU PRO 2000	3900	1350	1950	2230 Kg.
CU PRO 3000	4950	1350	1950	3230 Kg.
CU PRO 4000	5900	1350	1950	3630 Kg.
CU PRO 5000	6500	1350	1950	4050 Kg.
CU PRO 6000	7500	1350	1950	4850 Kg.



## 4.1. Instructions for unpacking and setting up

!! Take special care when lifting the load: The load may not be centered! To do this, use a forklift with blades long enough to support the machine, taking into account the width and depth of the machine for the calculation of the weights to lift.

Approximate gross weight of the machine (may vary depending on the equipment supplied):

Machine model	Weight (kg)
CU PRO 1000	1305 Kg.
CU PRO 1500	1730 Kg.
CU PRO 2000	2230 Kg.
CU PRO 3000	3230 Kg.
CU PRO 4000	3630 Kg.
CU PRO 5000	4050 Kg.
CU PRO 6000	4850 Kg.

To disassemble the packaging, remove only the 4 sides and the roof. Do not remove the wood from the feet (indicated in the photo with red arrows).





The machine is delivered with the base fixed to the lower wood for its transfer.

First, place the machine in its final location. Then remove the M12 hex bolts from the transport angle as shown in the following image.



Once the transport angle has been removed, put the M12 hexagon bolt back into place and tighten it.

Repeat this operation for all transport angles.







With the help of a hoist or a forklift, raise the machine to be able to move the wood to one side.

**IMPORTANT:** For your safety, do not remove the wood yet.



Use the supplied anti-vibration mounts to mount to and balance the machine.



Just below the machine, where the M12 hex bolt we removed earlier, are the mounting holes for the anti-vibration mounts.

First insert the M12 stud with the nut and washer as shown in the photo.



Once the stud is in place and adjusted to the required size, we can now thread the support.





Support threaded on the M12 stud.



Now tighten the M12 nut to the position needed to free the wood and the forklift.







M12 nut in position.



Once all the supports are in place, you can lower the forklift and remove the timbers.

Then you need to adjust the M12 nuts to the height you need to work.

NOTE: A lower position is more comfortable for loading/unloading the blades, and the machine is more stable.

Once the machine is located in its final location, you can now remove the protective film and other protections for components, which fixes and prevents the carriage from moving.

If the side tray is not assembled, assemble it by screwing in the two side screws as shown in the following picture:





## 5.INSTALLATION

### 5.1.Machine placement

Before any work we must make sure that the machine is well aligned and does not oscillate at any of its ends, in which case it must be wedged to avoid movements.

The machine must be perfectly level in the depth position (front-rear).

In the transversal position (left-right) it must have a slight drop towards the side where the coolant is evacuated, to better drain the machine bed towards the tank.

For its correct level it is necessary to use a spirit level. This check must be carried out both longitudinally and transversally.



Poorly leveling the machine can cause unwanted vibrations and premature wear of the linear guides.



**WARNING:** The machine must not be used under any circumstances by unqualified or unauthorized personnel.



## 5.2. Electrical connection



**DANGER HIGH VOLTAGE!**

Remember: before connecting the machine, remove any protection that the machine may have to protect the components during transport.

The ELITE model CU PRO grinding machine must be strictly connected to the voltage indicated in the machine order and on the machine itself. The connection to a voltage other than that indicated may cause a breakdown in the machine and represents a risk for people who use the machine.

This installation must be carried out by qualified technical personnel and checked with a voltage meter before turning on the machine.

It is absolutely essential that the cross-section of the connection cable is as required, that the machine has a dedicated outlet and is protected against overloads and shunts, and that it is as close as possible to the electrical outlet.

The electrical connection terminals have a red tape to facilitate correct connection.

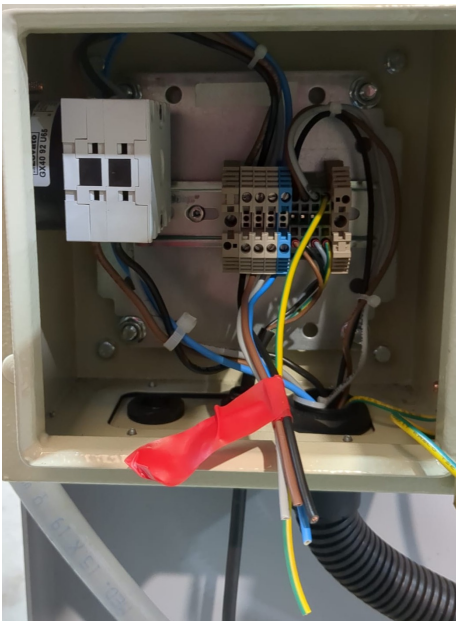

**ELITE does not assume any responsibility in the event of an incorrect electrical installation that may cause a malfunction of the machine and even personal or material damage.**



### 5.3. Main components of the machine

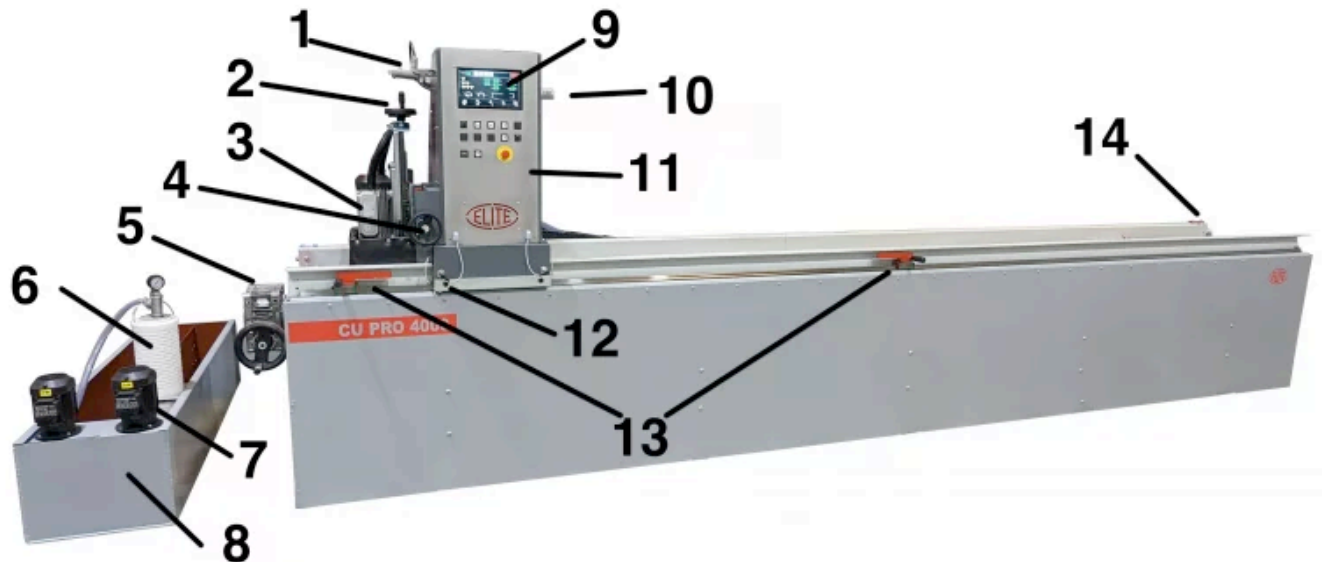

1. Led light
2. Manual adjustment of the raising or lowering of the second grinding wheel (optional)
3. Second grinding wheel motor (optional)
4. Regulation of the depth of the second grinding wheel motor (optional)
5. Adjustment of the inclination of the magnetic chucks
6. FILTRAMAQ UNO filtration system (optional)
7. Coolant pump motor (optional)
8. Cooling tank (optional)
9. LCD Screen
10. Manual adjustment of the raising or lowering of the grinding wheel
11. Control panel
12. Adjustment of the inclination of the main grinding wheel motor
13. Carriage travel adjustment stops
14. Carriage belt tension adjustment

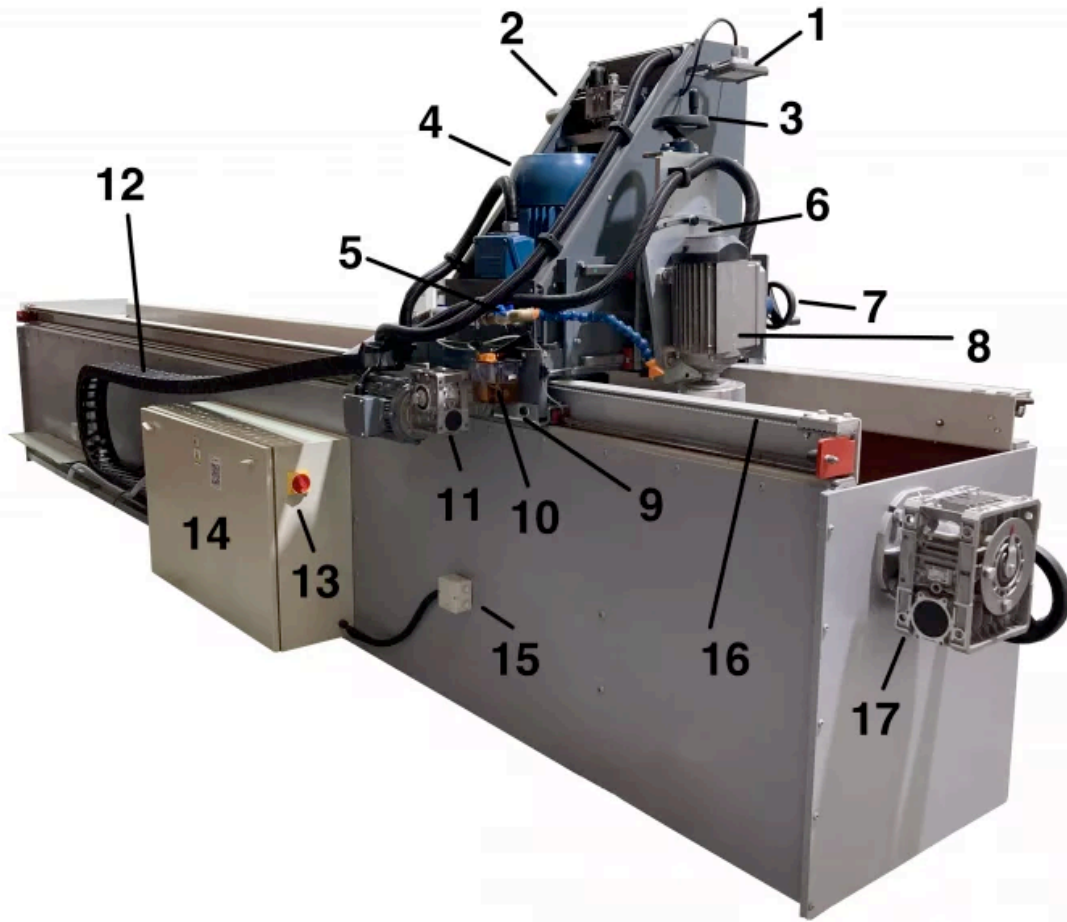

1. Led light
2. Manual lowering of the main grinding wheel
3. Manual lowering of the Z2 axis of the second grinding wheel motor (optional)
4. Grinding wheel main motor
5. Regulation of the coolant flow
6. Adjustment of the inclination of the second grinding wheel motor (optional)
7. Adjustment of the depth travel of the second grinding wheel motor (optional)
8. Second grinding wheel motor (optional)
9. Regulation of the inclination of the main motor of the grinding wheel
10. Manual centralized greasing
11. Carriage reducer motor
12. Transport chain for power cables
13. Main switch
14. Electrical panel
15. Connection box for magnetic plates
16. Carriage movement toothed belt
17. Adjustment of the inclination of the magnetic chucks



## 5.4. Control panel



1. LCD screen
2. Carriage speed selector
3. Carriage movement to the left
4. Carriage movement to the right
5. Z axis up
6. Z axis down
7. Speed regulator of second grinding wheel (optional)
8. START button
9. STOP button
10. Emergency stop



**For sections 6 to 8 of this manual, as well as for more up-to-date information and useful videos on the operation of the machine, please refer to our website**

**[www.elite.es](http://www.elite.es)**



[www.elite.es/en/support/manuals/cu-pro](http://www.elite.es/en/support/manuals/cu-pro)



## **9.ACCESSORIES AND CONSUMABLES**

### **9.1.Grinding wheels**

#### **9.1.1 Grinding wheel for carbide knives**

We recommend to use ELITE ref. nr. 3050-A. 6A2 Diamond  $\phi 250 \times 6 \times 3 \times 50 \times \phi 127$  mm.

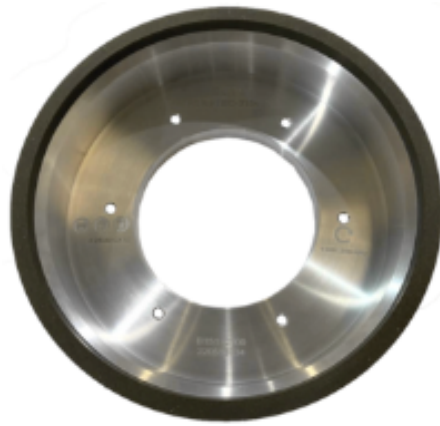

Grinding wheel for carbide knife

#### **9.1.1 Grinding for HSS knives**

We recommend to use ELITE ref. nr. 3150-A. 6A2H CBN  $\phi 250 \times 6 \times 6 \times 3 \times 50 \times \phi 127$  mm.

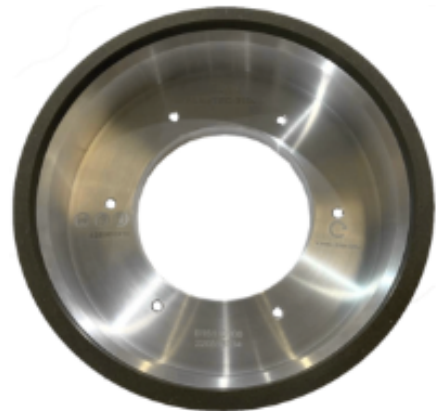

Grinding wheel for HSS knife





### 9.1.3. For steel knives

We recommend to use ELITE ref. nr. 3551-A. 6A2 Corundum  $\phi 200 \times 100 \times \phi 127$  mm.



Grinding wheel for steel knife

## 9.2. Coolant agents

### 9.2.1. Working for carbide or steel / HSS

We recommend to use ELITE SintoCut PRO MIX 200L or 20L or equivalent





## 9.2.2. Working with steel and HSS

We recommend to use ELITE SintoCut MIX 20L or equivalent



SintoCut MIX 20 L

## 9.3. Equipment

### 9.3.1. Filtering systems

Machine could be equipped with one of the following ELITE filtering systems. If your machine already has one of this systems and you need information or help, please refer to the manual of the filtering system.

#### 9.3.1.1. FILTRAmag UNO

An autonomous equipment for the filtration of grinding/sharpening liquids, up to  $2\mu\text{m}$ . It is ready to be installed inside the tank of ELITE model machines like CU or CU PRO.





### 9.3.1.2. FILTRAmag SOLO



Independent filtering system for one machine.

### 9.3.1.3. FILTRAmag PRO

Centralized filtering system for up to 5 machines.



### 9.4. Demagnetizer





[www.elite.es/en/support/manuals/cu-pro](http://www.elite.es/en/support/manuals/cu-pro)

**For more up-to-date information and useful videos on how to operate the machine, see our website [www.elite.es](http://www.elite.es)**